

### Typical Performance

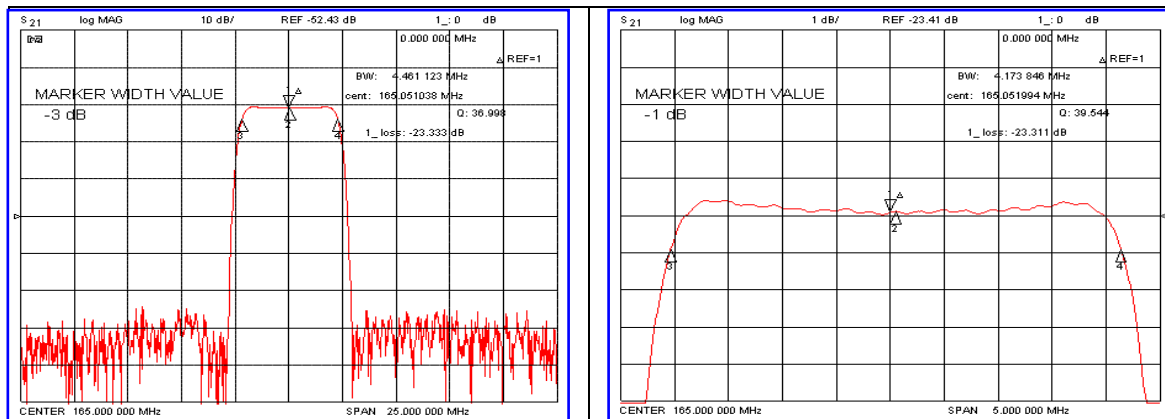

### Specification

Parameter	Unit	Min.	Typ.	Max.
Center Frequency	MHz	164.85	165.00	165.15
Insertion Loss	dB	-	23.50	25.00
1dB Bandwidth	MHz	-	4.17	-
3dB Bandwidth	MHz	4.30	4.46	-
40dB Bandwidth	MHz	-	5.55	5.70
Passband Ripple	dB	-	0.50	1.00
Group Delay Variation	nsec	-	55	100
Absolute Delay	µsec	-	2.25	-
Ultimate Attenuation	dB	50	55	-
Substrate Material	-	Quartz		
Temperature Coefficient	ppm/°C <sup>2</sup>	-0.03		

### Package Dimension

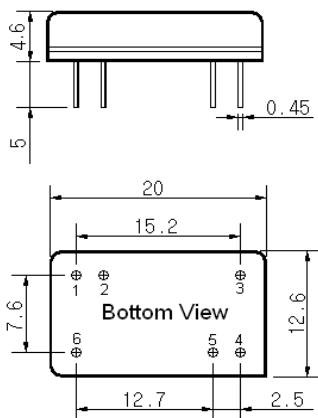

### Matching Configuration

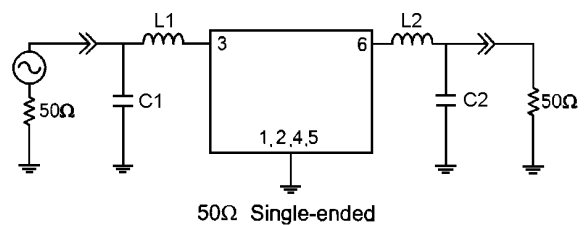

L1= 56nH, L2=47nH, C1=39pF, C2=47pF  
 Source / Load Impedance = 50Ω  
 Ambient Temperature = 25°C

11/13/2006

