

### Typical Performance

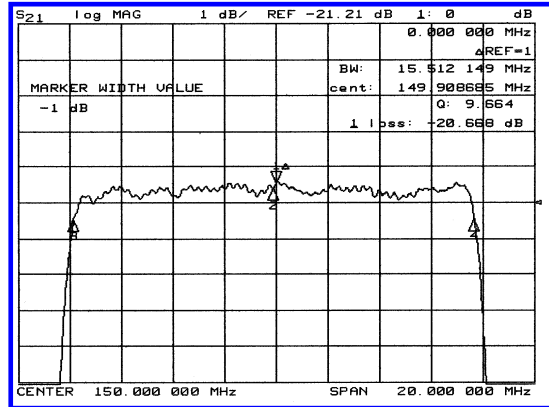
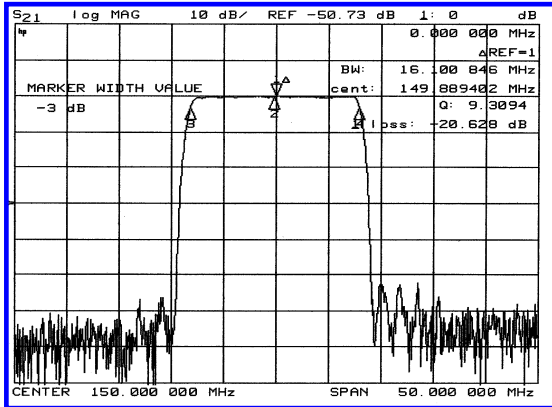

### Specification

Parameter	Unit	Min.	Typ.	Max.
Center Frequency	Mhz	149.80	150.00	150.20
Insertion Loss	dB	-	20.50	22.00
1dB Bandwidth	MHz	15.35	15.50	-
3dB Bandwidth	Mhz	16.00	16.10	-
40dB Bandwidth	Mhz	-	18.30	18.60
Passband Ripple	dB	-	0.65	1.00
Group Delay Variation	nsec	-	100	200
Absolute Delay	µsec	-	1.66	-
Ultimate Attenuation	dB	50	55	-
Substrate Material	-	YZ-LiNbO <sub>3</sub>		

### Package Dimension

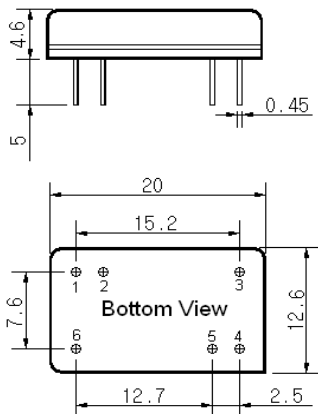

### Matching Configuration

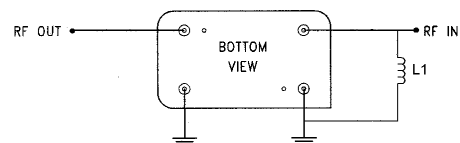

L1 = 68nH  
 Source / Load Impedance = 50Ω  
 Ambient Temperature = 25°C

05/14/2002