

Typical Performance

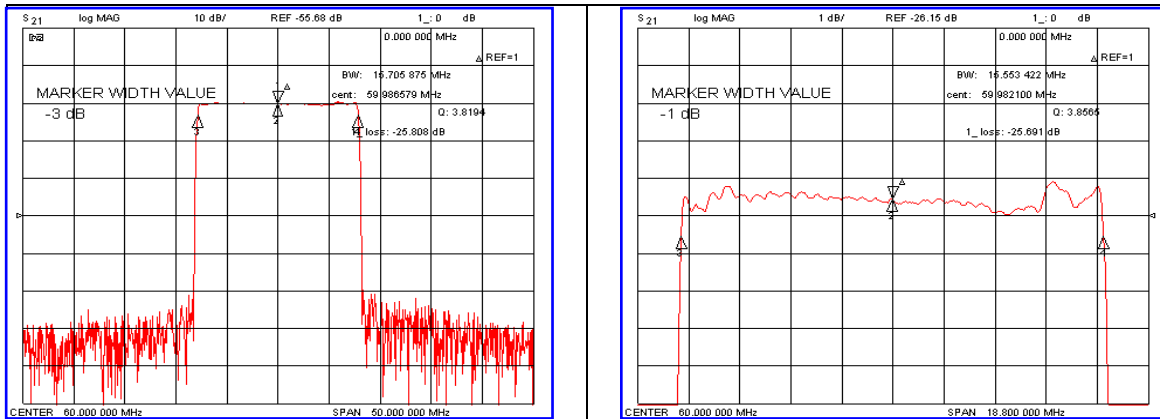

Specification

Parameter	Unit	Min.	Typ.	Max.
Center Frequency	MHz	59.92	60.00	60.08
Insertion Loss	dB	-	25.80	27.50
1dB Bandwidth	MHz	15.50	15.55	-
3dB Bandwidth	MHz	-	15.70	-
20dB bandwidth	MHz	-	16.16	16.25
40dB Bandwidth	MHz	-	16.37	16.50
Passband Ripple	dB	-	0.88	1.10
Group Delay Variation	nsec	-	100	200
Absolute Delay	usec	-	4.01	-
Ultimate Attenuation	dB	48	50	-
Substrate Material	-	128-LiNbO ₃		
Temperature Coefficient	ppm/°C	-72		

Package Dimension

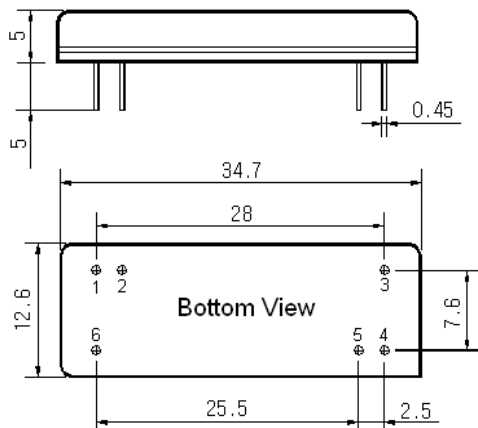

Matching Configuration

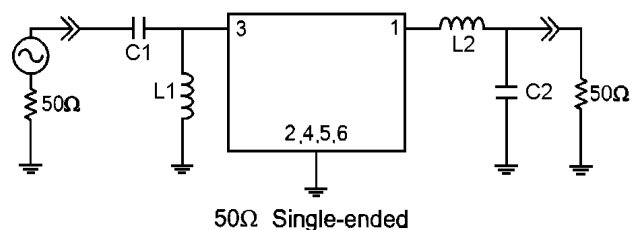

L1=120nH, L2=180nH, C1=68pF, C2=5.6pF
 Source / Load Impedance = 50Ω
 Ambient Temperature = 25°C

Rev.0 091019

