

Typical Performance

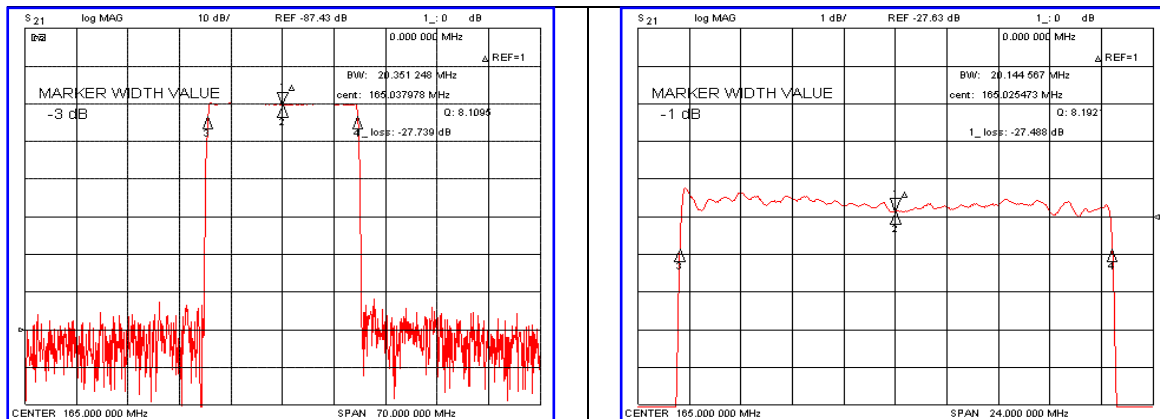

Specification

Parameter	Unit	Min.	Typ.	Max.
Center Frequency (Fo)	MHz	164.85	165.00	165.15
Insertion Loss	dB	-	27.80	30.00
1dB Bandwidth	MHz	20.00	20.14	-
3dB Bandwidth	MHz	-	20.35	-
25dB Bandwidth	MHz	-	21.04	21.15
35dB Bandwidth	MHz	-	21.17	21.30
45dB Bandwidth	MHz	-	21.29	21.40
Ultimate Rejection	dB	48	52	-
Amplitude Ripple	dB	-	0.80	1.20
Absolute Delay	usec	-	3.91	-
Substrate Material	-	112-LiTaO ₃		
Temperature Coefficient	ppm/°C	-20		

Package Dimension

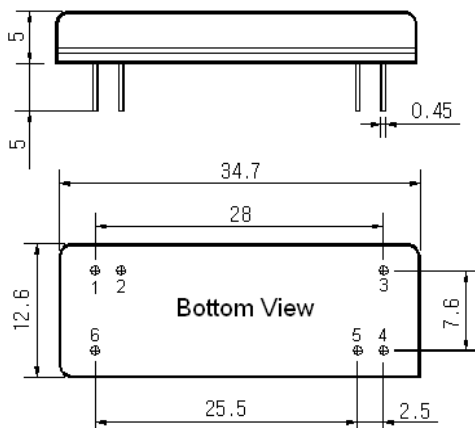

Matching Configuration

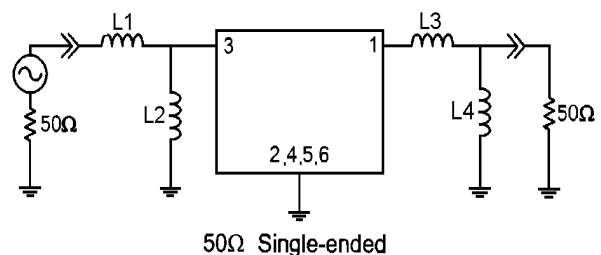

L1=27nH, L2=27nH, L3=5.6nH, L4=15nH
 Source / Load Impedance = 50Ω
 Ambient Temperature = 25°C

Rev.0 100222

