

Typical Performance

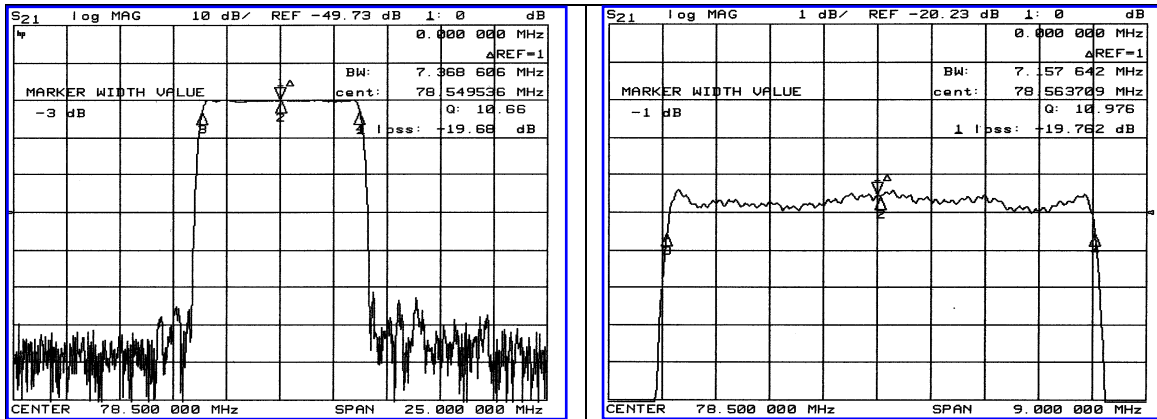

Specification

Parameter	Unit	Min.	Typ.	Max.
Center Frequency	MHz	78.42	78.50	78.58
Insertion Loss	dB	-	19.50	22.00
1dB Bandwidth	MHz	-	7.15	-
3dB Bandwidth	MHz	7.30	7.36	-
20dB Bandwidth	MHz	-	7.94	-
45dB Bandwidth	MHz	-	8.23	-
Passband Ripple	dB	-	0.65	1.00
Group Delay Variation	nsec	-	100	200
Absolute Delay	µsec	-	3.61	-
Ultimate Attenuation	dB	50	55	-
Substrate Material	-	YZ-LiNbO ₃		
Temperature Coefficient	ppm/°C	-94		

Package Dimension

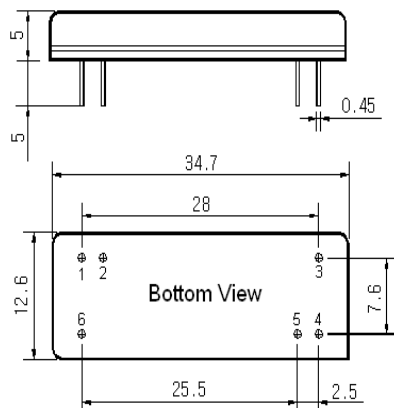

Matching Configuration

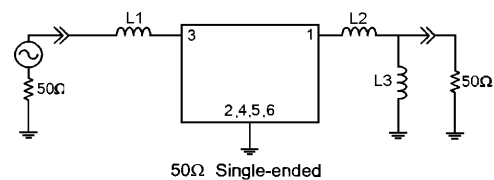

L1=220nH, L2=6.8nH, L3=220nH
 Source / Load Impedance = 50Ω
 Ambient Temperature = 25°C

09/02/2005

