

Typical Performance

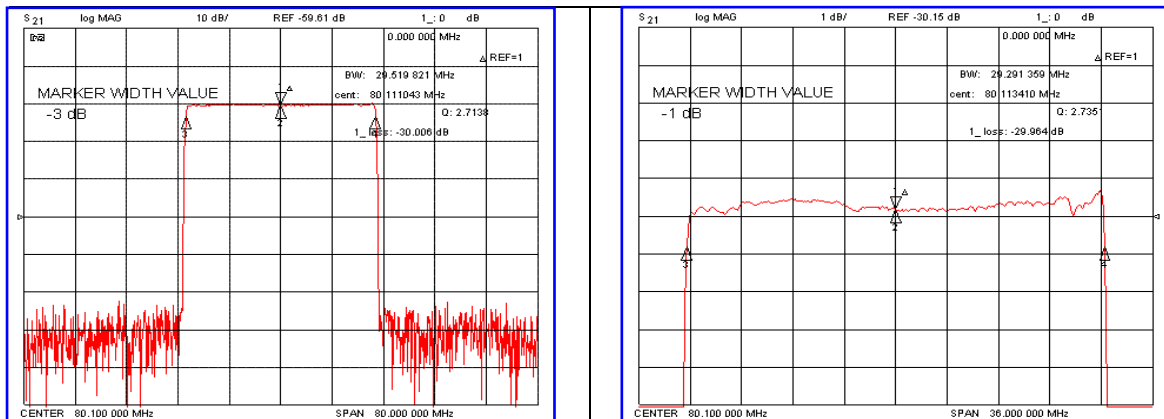

Specification

Parameter	Unit	Min.	Typ.	Max.
Center Frequency	MHz	80.02	80.10	80.18
Insertion Loss	dB	-	30.00	32.00
1dB Bandwidth	MHz	29.15	29.29	-
3dB Bandwidth	MHz	-	29.51	-
40dB Bandwidth	MHz	-	30.40	30.50
Passband Ripple	dB	-	0.65	1.00
Group Delay Variation	nsec	-	50	100
Absolute Delay	usec	-	3.36	-
Ultimate Attenuation	dB	48	52	-
Substrate Material	-	128-LiNbO ₃		
Temperature Coefficient	ppm/°C	-72		

Package Dimension

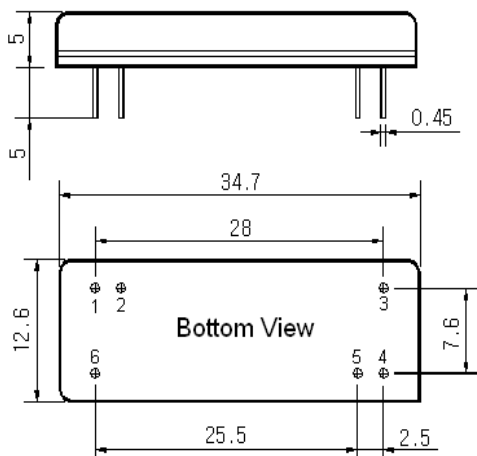

Matching Configuration

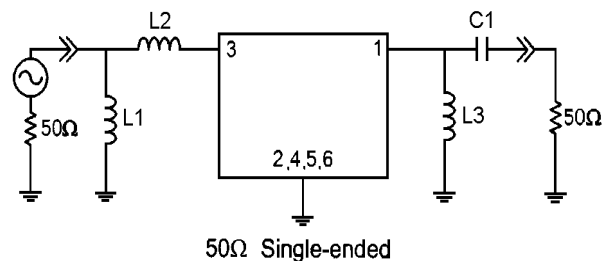

L1=120nH, L2=68nH, L3=82nH, C2=62pF
 Source / Load Impedance = 50Ω
 Ambient Temperature = 25°C

Rev.0 100413

